

MIRA Field-Mulling Instructions

For Joining Ply Gem MIRA Aluminum-Clad Wood Windows

Recommended Tools & Accessories

- Tape Measure
- Level (3' or longer)
- Hammer
- Wood Block (~1" x 2" x 8")
- Utility Knife
- Hack Saw
- Drill with Phillips and ¼" drill bit
- 1 or 2 Soft-footed C-clamps
- Shims
- Diagonal cutters (Dikes for X- & T-Mulls)
- Sealant (Silicone recommended)
- Fasteners (See instructions attached to the windows for details)
- Ply Gem Mull Kit Part #:
 - Horizontal ≤ 7ft: #253813
 - Horizontal > 7ft: #253814
 - Vertical ≤ 7ft: #253815



IMPORTANT! READ ALL INSTRUCTIONS BEFORE BEGINNING INSTALLATION.

Verify that your mull kit contains the components shown at the bottom of this page, and that the colored components in your kit match your window units.

Check the windows thoroughly for possible transit damage, proper operation, and mull orientation. Follow your local building codes, customs and building practices for additional installation requirements. Ply Gem Windows warrants this product only when assembled according to these instructions and installed with the instructions affixed to each window unit. A design or building professional may be consulted as necessary. **Ply Gem Windows will accept no responsibility for air or water leakage above, under, or around the window unit. If the mull joint is assembled per these instructions, the mullion will be rated to the design pressure indicated by the mullion label affixed to the unit.**

MIRA mulls come with two levels of reinforcement: high performance and standard performance. High performance reinforcements are only needed on very large combinations. Refer to the illustration at right to determine which reinforcement you have. Both reinforcements are compatible with the standard mull kit, but they must match each other from unit to unit to engage properly. **When you receive your window units, the nail fin will have already been trimmed off for the mull joint and, in most cases, the reinforcement will have been attached already.**

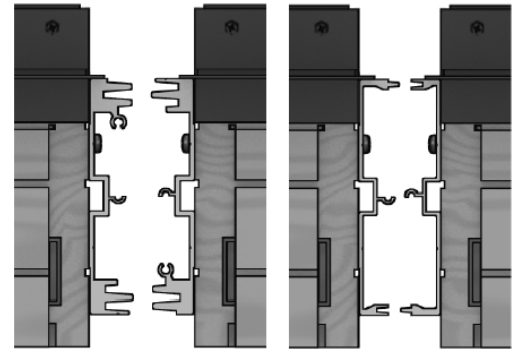

High Performance

Standard

Assembly Preparation: These instructions focus on assembly of the mull only. With this kit, the window units are mulled into a single assembly that can then be mounted into the rough opening.

Field Mull Assembly Table of Contents

Side by Side or Transoms	PAGE 2	
T-Mull or X-Mull	PAGE 5	
Precautionary Notes	PAGE 6	
Appendix A: Field-Applied Reinforcements	PAGE 7	

Please refer to the instructions included with the individual window units for recommendations and procedures for mounting and sealing the window assembly (in the rough opening). **It is expected that you will follow all recommended procedures to prepare the rough opening before beginning the assembly procedure in these instructions.** Follow the Table of Contents at left to determine which instructions to follow in this document.

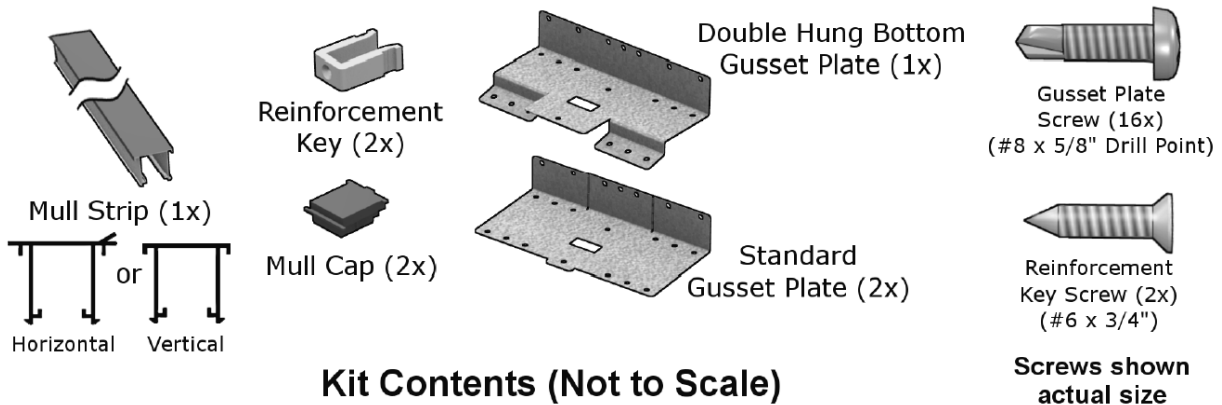

Side-by-Side or Transom Assemblies

These instructions use a double hung side-by-side assembly as the primary example. If you are not using a double hung or double hung stationary unit, then you will not need the double hung bottom gusset plat (shown in kit contents on page 1, but you will need both standard gusset plates. The assembly procedure is basically identical for either plate. These instructions may be used for mulling any type of unit, including transom-to-door mulls.

1a) Place the window units, exterior face up, on a clean, flat work surface, with the mull-prepared sides adjacent to each other.



If you are assembling Operating Casement or Awning units, be careful not to rest the operator on the work surface. Overhang the operator off of the work surface to prevent damage, or support by using scrap blocking around the perimeter of the frame to prevent the operator from resting on the work surface thus preventing any damage.

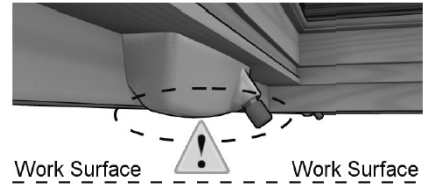

1b) Slide the units together as close as possible by hand so the reinforcements engage. Then insert a Reinforcement Key in both ends, and fasten with the included screws. A light hammer tap may be required to firmly set the key in all the way.

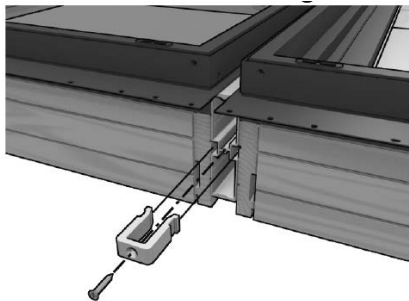

1c) Apply a liberal amount (1/4" bead minimum) of sealant along the full mull span, on the visible edge of the reinforcements. Then use a shim or putty knife blade to flatten it out to make a complete seal, leaving no gaps in the sealant.

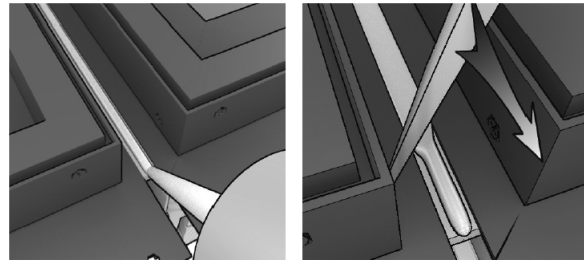

1d) The mullstrip comes as a lineal strip, and must be cut to length to fit the assembly. Cut the strip as squarely and cleanly as possible, making it 7/16" shorter than the unit size shown.

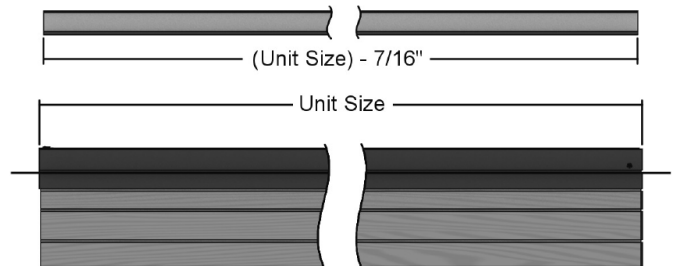

1e) Verify the length by dry-fitting the mull caps into both ends and laying the mullstrip upside down on the units. Both ends should be flush within 1/16".

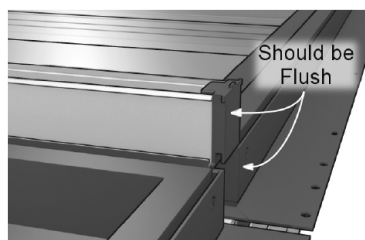

1f) (For Horizontal Mullstrip Only)

The horizontal mullstrip needs to be wept for proper water drainage. Using a drill with a 1/4" drill bit, follow the illustration below to create a hole approximately every three feet in the top leg only. Start an arbitrary distance from one end.

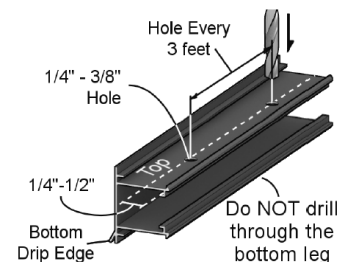

1g) Once the mullstrip has been cut to the correct length, keep the mullstrip upside down and apply a continuous 1/8" bead of sealant along the full length of each accessory groove leg as shown.

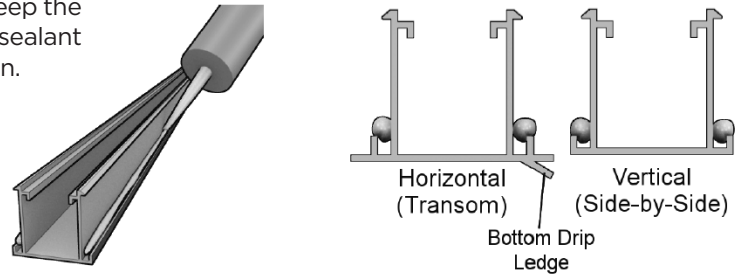

1h) Flip the mullstrip back over and move it into place. **It should be centered end-to-end in the gap to allow the mull caps at each end.** If you are installing a horizontal mullstrip, make sure the drip ledge will be on the bottom edge when installed. Starting at one end, squeeze the legs together so that you can press the strip into the gap between the units. Press the mullstrip in as far as you can by hand from end to end.

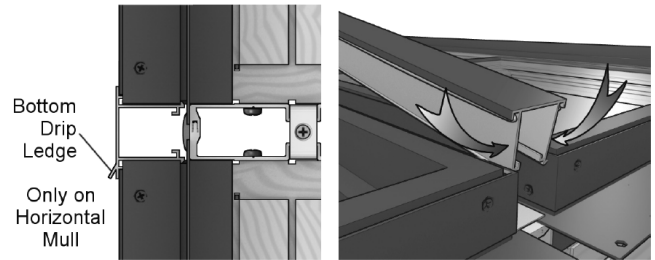

1i) It may be necessary to gently lift up on the outer edges of the windows to bring them close enough to engage the mullstrip. Additionally, one or more soft-footed clamps may be used to clamp the cladding of the two units together so the mull reinforcements are completely interlocked. Starting from one end, use a hammer with a wood block to tap the mullstrip into the accessory grooves (be careful not to damage the mullstrip surface by hammering too hard). The vertical strip should be flush with both frames, and the horizontal strip should not have any gaps against the Frames. **If the mullstrip is too far to one end or the other, we will address that in a later step.**

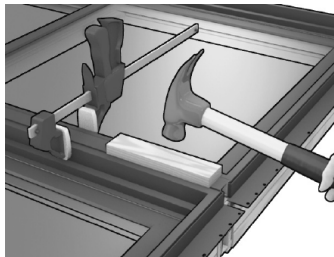

1j) Determine which two plates you need based on your units:

Side-by-Side Double Hung or DH Stationary:

- 1 Standard Gusset Plate +
- 1 Double Hung Bottom Gusset Plate

All other joints:

- 2 Standard Gusset Plates

Transom Shapes:

All shapes use the Standard Gusset Plate with their marching window unit. The gusset plate will need to be bent as shown to follow the curvature of the nail fin.

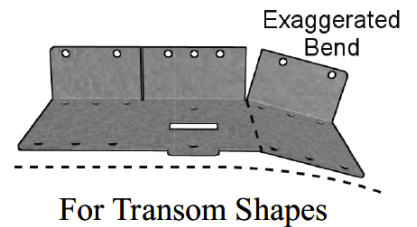

1k) Apply a generous amount of sealant to the folded edge of the two gusset plates needed, and apply 4 beads as shown. The outer beads should be aligned with holes, and the inner one should be aligned with the split, or spaced as shown in the Double Hung Gusset Plate. Make sure to cover the splits completely on the Standard Gusset Plate. If the Standard Gusset Plate is bent for a transom shape, create a 'V' bead to cover both edges of the split.

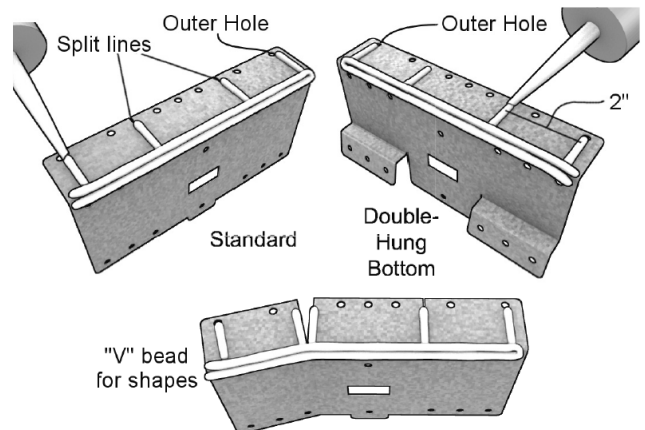

1l) Push the gusset plates onto the jambs until the reinforcement key comes through the square opening in the gusset plates.

Double Hung
& Double Hung
Stationary Sill

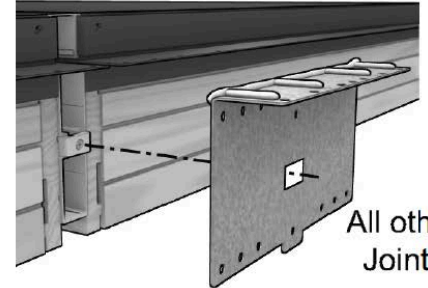
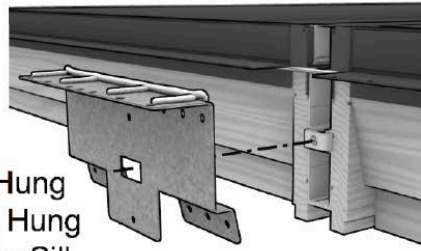

All other
Joints

1m) Beginning with the screws nearest the nailfin, fasten each gusset plate using 8 included gusset plate screws. On the Standard Gusset Plate, add silicone to the two splits if you don't see a squeeze-out of silicone.

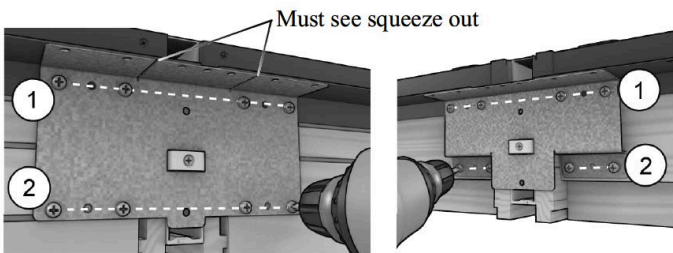

1n) (Double Hung Only): If you are mulling double hung units, use a utility knife to snap off the two tabs on the interior side of ONE mull cap. **This mull cap will install on the bottom (sill) end of the mull.**

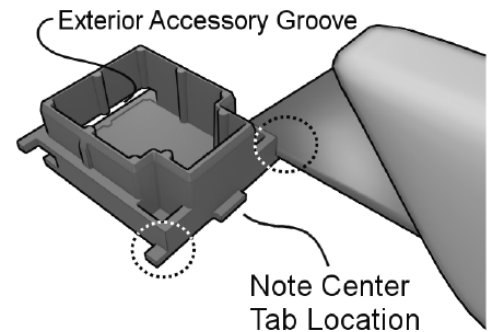

1o) Apply generous sealant on the sides and against the nailfin as shown. **Do not seal the front (exterior) edge of the mull cap.** When the mull cap is installed, there should be a small amount of sealant squeeze-out around the mull caps.

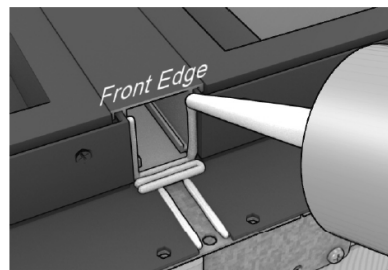

1p) If you do not see sealant squeeze-out around the mull cap, apply it as needed around the edges of the mull cap to completely seal the joint, except for the front (exterior) edge. The slot in the front edge is needed to weep water away from the windows.

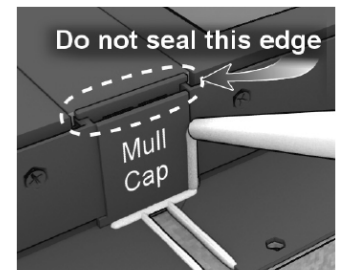

1q) The mull caps should be within 1/16" of being flush at both ends. If they are not, use a hammer and wood block to tap on the protruding mull cap until the mull strip is centered end-to-end.



1r) The mulled unit is now complete and may be fastened to the wall. Refer to the section "Mulled Combination Installation" on the installation instructions that come with the individual window units.

Your Side-by-Side or Transom Mull is complete!

Please Read the Precautionary Notes on Page 6 before continuing.

T-Mull or X-Mull Assemblies

These instructions focus on the X-mull, but a T-mull is identical except that there is no vertical mull above the horizontal mull.

2a) In some cases, the mull reinforcement will be shipped without being attached to the units, and you will have to attach it yourself. This would be true, for example, if you were going to field mull a twin and then apply a transom. The reinforcement can be found attached to its matching part using two reinforcement keys (see illustration). Simply remove the screw and key at each end to remove the reinforcement (reference Step 1b).



(Only necessary on some combinations)

2b) If there are reinforcements that need to be attached, you will need to refer to Appendix A on page 7. Once you're finished attaching the reinforcement, return to step 2c.

2c) If the horizontal reinforcements in this combination fully span the rough opening (see Illustration A at right), then the side-by-side units will be assembled first. If the vertical mullions fully span the rough opening (see Illustration B at right), then the over-under combinations will be assembled first. Most combinations will follow Illustration A.

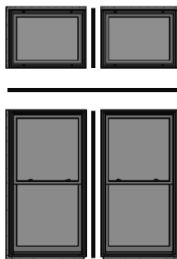

Illustration A

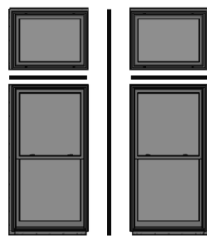
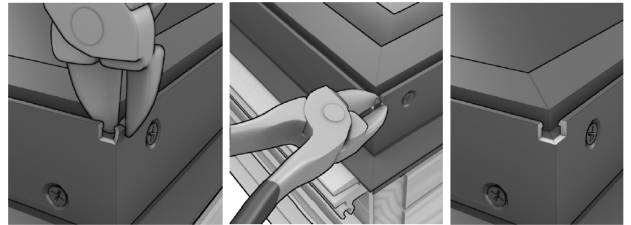
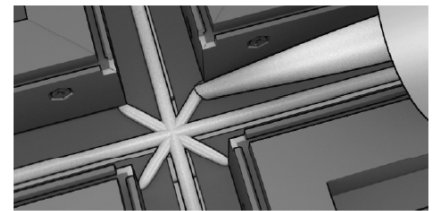

Illustration B

2d) Locate the corner on each unit that will be at the X intersection. Using a side cutter or similar tool, snip out 1/8" of the accessory groove in the corner of the exterior cladding as shown. Be careful not to damage the exterior surface of the unit. Repeat this on the other three units at the X intersection corner.



2e) Follow Steps 1a and 1c to join all the units together in stages as described in step 2c. On step 1c, apply sealant as shown to assure a full seal at the corner. Apply sealant in an X overtop of the nail fin miter joints. Then flatten the sealant with a shim or putty knife as described in that step. The sealant should be continuous with no gaps.



2f) The mullstrips must be cut to length to fit the assembly. Cut each strip as squarely and cleanly as possible, cutting it per the table below. Mullstrips will always follow the arrangement shown regardless of the reinforcement orientation. You can lay the mullstrip upside down on the joint to easily check the length against the window units (refer to step 1e). Cut a mullstrip for each vertical joint above and below each horizontal joint. Make sure you use the correct mullstrip profile for each joint (compare profiles under the parts list on page 1).

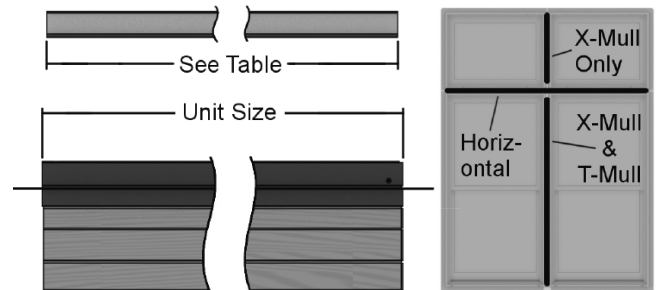

Mull Strip Type	Cut Length
Vertical	(Unit Height) - 3/8"
Horizontal	(Assembly Width) - 7/16"

2g) (For vertical Mullstrips): It is recommended that you test fit the vertical mullstrips by laying them upside down along the accessory grooves and include the mull caps at the ends (see illustration). Install the vertical mullstrips by following steps 1d through 1q.

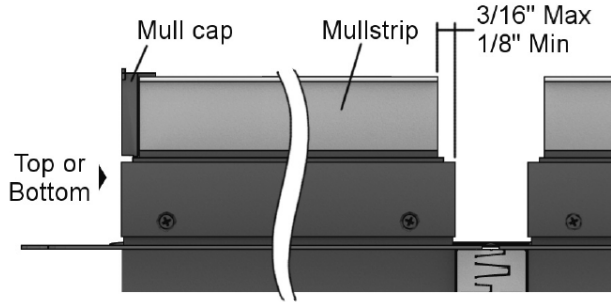

2h) (For Horizontal Mullstrips): Apply sealant to the underside of the mullstrip as shown (reference step 1e). In addition, a small bead of sealant is needed on both vertical mullstrips where the horizontal mullstrip overlaps them (see figure).

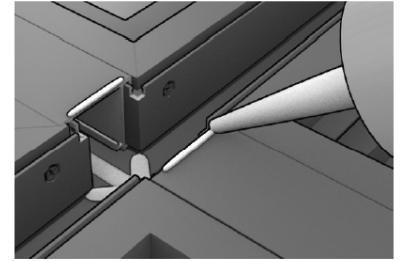
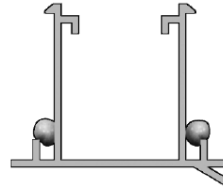

2i) At each perimeter mull joint, install the gusset plates as described in steps 1j through 1m and install mull caps as described in steps 1n through 1q.

2j) The mulled unit is now complete and may be fastened to the wall. Refer to the section “Mulled Combination Installation” on the installation instructions that come with the individual window units.

Your X- or T- Mull is complete!

Please read the Precautionary Notes below before continuing.

Precautionary Notes



- Mullled Combinations are very heavy. Please use adequate help and equipment to prevent personal injury or damage.
- The DP rating will only be guaranteed on this mull assembly if it is assembled and installed according to these instructions and the individual unit instructions, including fastener types. Refer to the individual installation instructions for fastener specifications on the rest of the unit.
- Ply Gem Windows warrants this product only when installed according to these instructions in conjunction with the instructions affixed to each window unit. A design or building professional may be consulted as necessary.
- Ply Gem Windows will accept no responsibility for air or water leakage above, under, or around the window unit.

Other instructional resources for MIRA products:

MIRA single- and mulled-unit installation instructions: PGW # 170024000

MIRA mullstrip removal instructions: PGW # 253802

Appendix A: Field-Applied Reinforcements

Ply Gem Windows warrants this product only when installed according to these instructions in conjunction with mull assembly instructions and the instructions affixed to each window unit.

Depending on the configuration of your window combination, it may have been necessary to ship your units without one or more aluminum reinforcements attached. If this is the case, the reinforcement will need to be applied to the combination onsite. These steps will walk you through the application of the reinforcement.

3a) The mating mull reinforcements must be installed so that they interlock. Orient the unattached reinforcement to the units so that it matches the reinforcement attached to the other window units. The high performance reinforcement is shown below left, and standard reinforcement is shown below right.

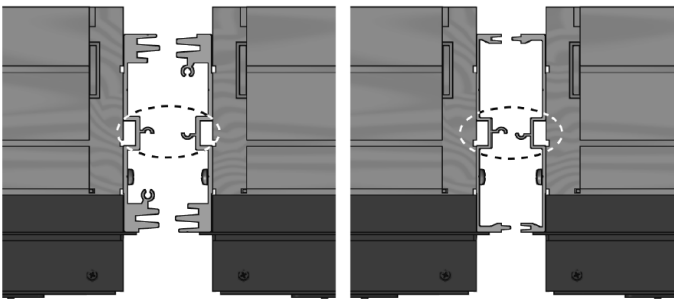

3b) If the reinforcement is spanning multiple units, you may need to remove temporary gusset plates, wood reinforcers, etc. The Reinforcement Key should be the only component protruding from the surface of the window units.

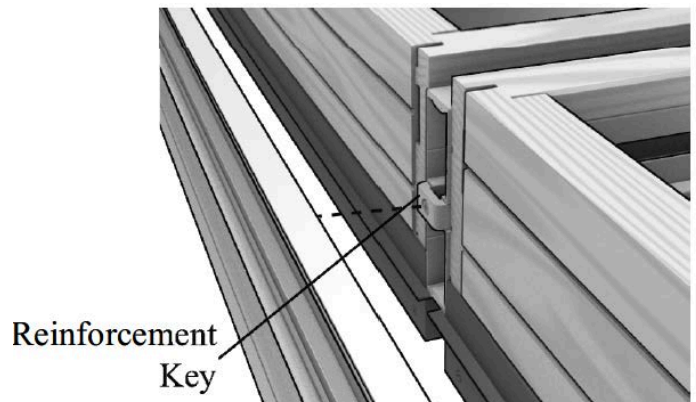

3c) Taking care not to scuff the exterior of the surface of the windows, place the assembly exterior side down. Place the reinforcement against the units so that it is evenly centered and end-to-end, and interlocking with any reinforcement keys. The reinforcement finger orientation shown at right will not necessarily be the same as your reinforcement.

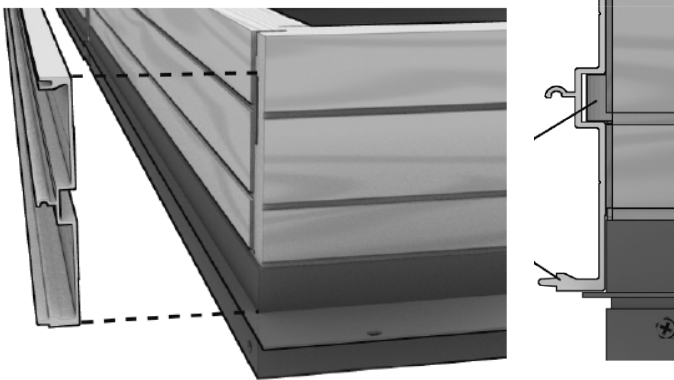

3d) Using the #8 drill-pointed screws provided, start 2 inches from each end of each unit in the assembly, and install the screws a maximum of 8 inches apart. Make sure to use the correct scribe line based on the product (see below).

All non-Casement Products

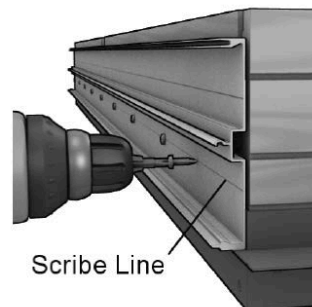

Casement & Awning Products

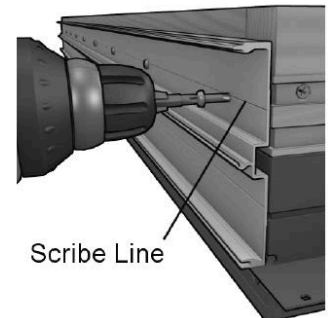

Your units are ready to be mullled!